

# RS 232 communication

**Configuration**  
**NTK – KK Controller**

## 1. Table of contents

|        |                                       |    |
|--------|---------------------------------------|----|
| 1.     | Table of contents.....                | 2  |
| 2.     | Introduction.....                     | 3  |
| 3.     | Nordtank – KK controller.....         | 4  |
| 3.1.   | Parameters.....                       | 5  |
| 3.2.   | Remote commands.....                  | 6  |
| 3.3.   | Hardware.....                         | 7  |
| 3.3.1. | Serial drivers.....                   | 7  |
| 3.3.1. | The U253 switch.....                  | 8  |
| 3.3.2. | The R97 jumper .....                  | 8  |
| 3.3.3. | Verify power and serial drivers ..... | 9  |
| 3.3.4. | Communication slot C5 .....           | 10 |
| 4.     | Cable.....                            | 12 |
| 4.1.   | Cable layout for F2403 .....          | 12 |
| 4.2.   | Cable layout for F2816 - COM 1.....   | 13 |
| 4.3.   | Cable layout for F2816 - COM 2.....   | 13 |
| 5.     | Four Faith – Signal monitoring.....   | 14 |
| 5.1.   | F2403 Signal monitoring .....         | 14 |
| 5.2.   | F2816 Signal monitoring .....         | 15 |

## **2. Introduction**

This document shows how to enable RS232 communication on a Nordtank turbine with KK controller.

The document includes:

- How to change parameter and which settings needs to be changed.
- Hardware updates and changes.
- What new hardware is needed.
- Cable connections.

## 3. Nordtank – KK controller

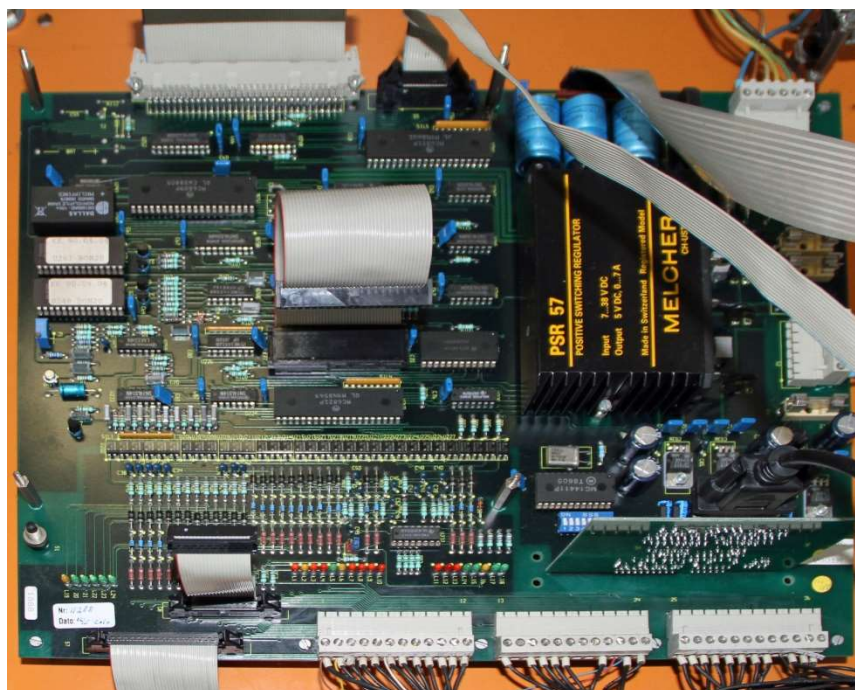

## 3.1. Parameters

The following parameters must be configured:

Address:

- Turbine ID            " A3E3"=01 (and 02 for the second turbine)
- Dialback on/off     " A2F2"=0
- Master WTG         " A2F4"=1
- Password            " A2F6"=0



The parameters are changed by using the following procedure:

- |   |                                    |
|---|------------------------------------|
| 1. Turn the key into service                          |                                    |
| 2. Press the red "stop" button                        | The display shows "Service ON"     |
| 3. Press the yellow "Motor start" button              | The display shows "A"              |
| 4. Press the blue "<Yaw" button                       | The display shows the addressee    |
| 5. Enter the selected address                         |                                    |
| 6. Press the blue ">Yaw" button to change value       | The display show the present value |
| 7. Enter the new value                                |                                    |
| 8. Press the green "Start" button to accept input     |                                    |
| 9. Repeat step 4 to 8 until all parameter are changed |                                    |
| 10. Turn the key back into normal                     |                                    |

When in service mode is the keyboard transformed into a Hex keyboard:



|   |   |   |   |               |      |
|---|---|---|---|---------------|------|
| A | 7 | 8 | 9 | Addr          | Data |
| B | 4 | 5 | 6 | Memory change |      |
| C | 1 | 2 | 3 | Return        |      |
| D | E | F | 0 | Stop          |      |

If the control values on a DWP turbine are reset, please use the code 10101 on address A3C6. The turbine will display error "36 ude af dr"

## 3.2. Remote commands

Remote commands can be enabled or disabled on the controller panel.



|   |   |   |   |             |      |
|---|---|---|---|-------------|------|
| A | 7 | 8 | 9 | Addr        | Data |
| B | 4 | 5 | 6 | Motor start |      |
| C | 1 | 2 | 3 | Start       |      |
| D | E | F | 0 | Stop        |      |

Press the E key in normal mode to display the program version, Turbine id number and Remote commands available:

|          |                        |            |
|----------|------------------------|------------|
| PGM REV  | ** TURBINE NAME-TYPE** | W.E.C. NO. |
| YY.MM.DD | REM.ON                 | 0          |

The display shows:

- Program version date is listed to the left.
- Turbine Id no. is listed to the right.
- The Turbine name and type is listed in the middle of the top line
- The state of the remote commands is listed in the middle on the second line.
  - REM.ON Remote commands are activated
  - REM.OFF Remote commands are disabled

Remote access can be toggled on and off by pressing the F key.

## 3.3. Hardware

### 3.3.1. Serial drivers

U254 and U255 must be mounted before the serial communication works. They are not necessarily mounted if the turbine has been operating without communication.

There is only one type: U254 is a MC6850 and

U255 is a MC14411

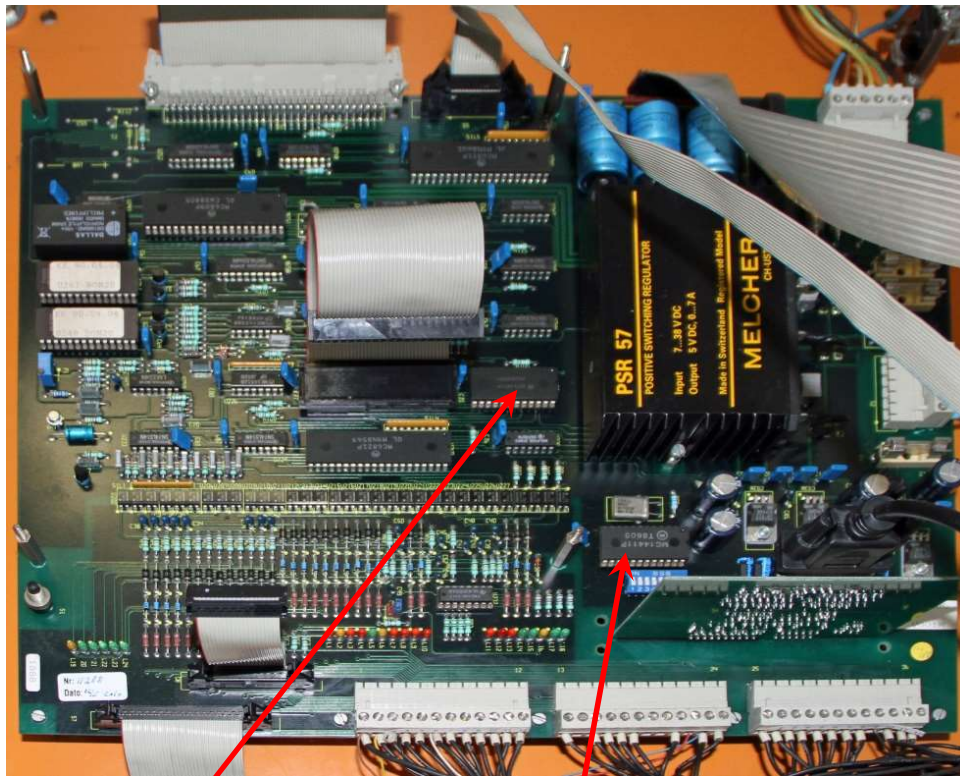

U254 is a MC6850

U255 is a MC14411

**PLEASE NOTE THAT THE U254 and U255 MUST NOT BE REMOVED, INSTALLED OR REPLACED WHEN THE CONTROLLER IS POWERED UP. PLEASE REMOVE POWER BEFORE WORKING ON THE COMPONENTS.**

### 3.3.1. The U253 switch

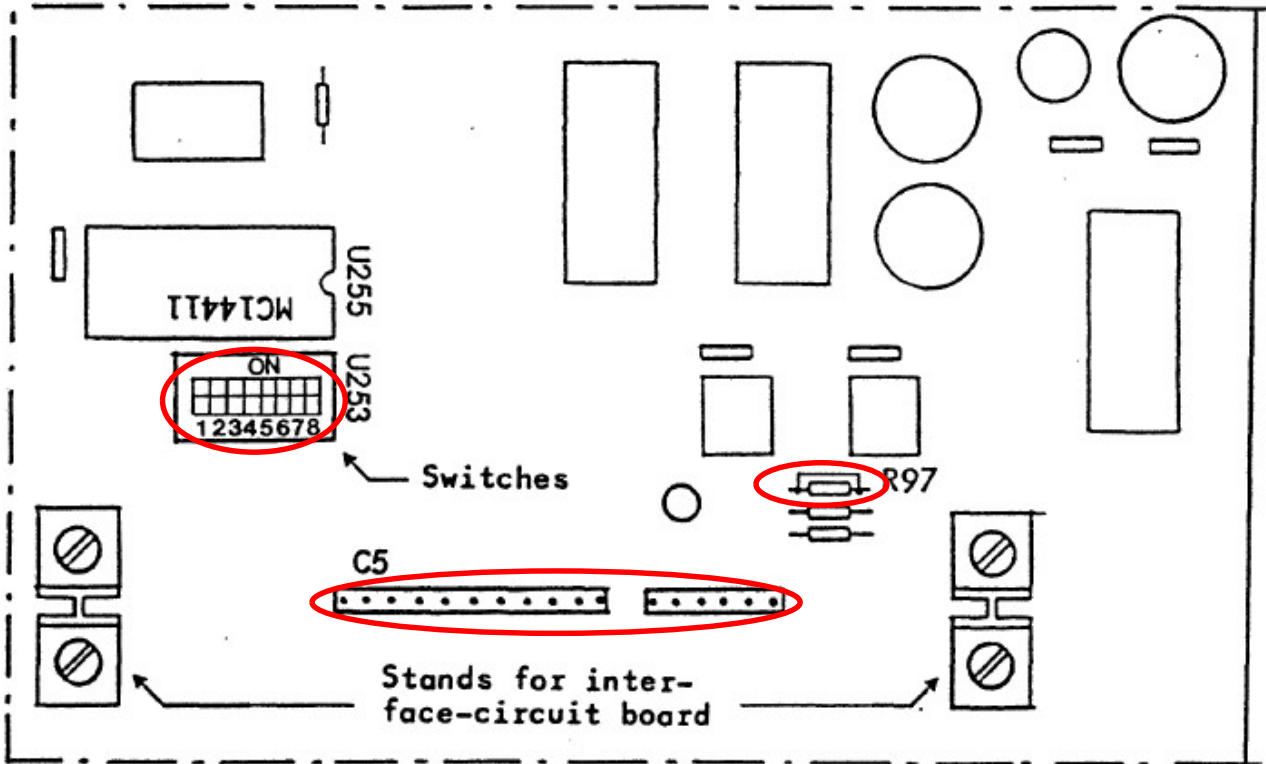

The U253 dipswitch sets the communication speed:

| switch "ON" | baud-rate |
|-------------|-----------|
| 1           | 110       |
| 2           | 150       |
| 3           | 300       |
| 4           | 600       |
| 5           | 1200      |
| 6           | 2400      |
| 7           | 4800      |
| 8           | 9600      |

### 3.3.2. The R97 jumper

R97 jumper must be shorted to power the communication board.

## 3.3.3. Verify power and serial drivers

The power and the serial drivers can be verified on the C5 connector by measuring:

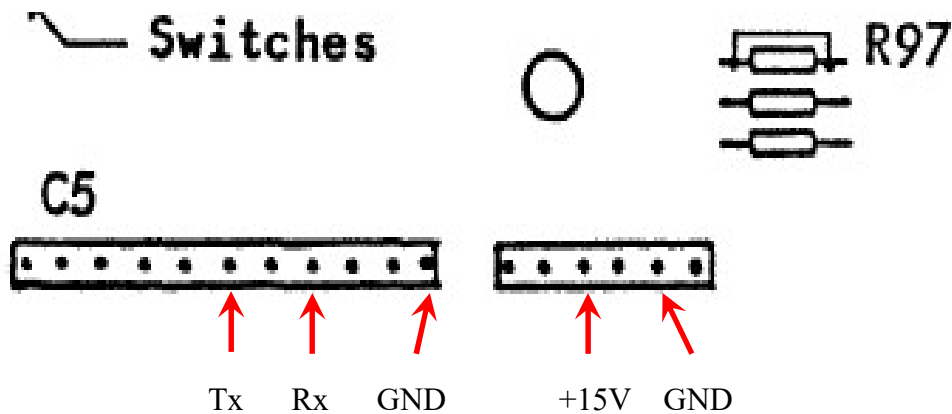

If the +15 V power is missing can there be a problem with:

- The short over the R97 resistor
- The fuse beneath the power connector
- The 24 V AC power supply

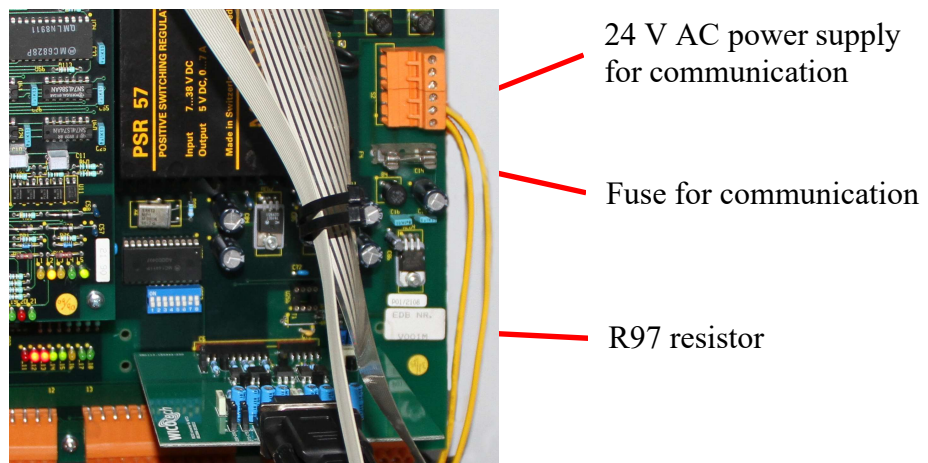

If the U254 and U255 is mounted correct must there be a voltage between the Tx pin and the GND pin on the left side of the C5 connector. If no voltage is measured are the components not mounted or defect.

## 3.3.4. Communication slot C5

The serial communication card must be installed in communication slot C5.

VK0331GB or the WICotech RS232 interface card may be used.

The WICotech card is preferred since it may be connected to the modem using standard cables.

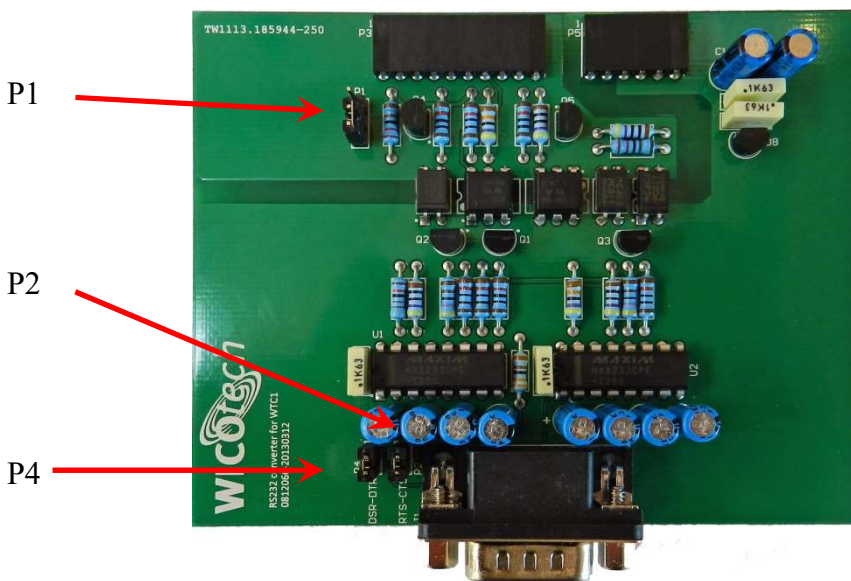

WICotech RS232 interface card

Jumpers on the WICotech RS232 interface card:

- |     |             |   |
|-----|-------------|---|
| P1: | 1-2 shorted | Pin 8 is always low on the RS232 connector.<br>Default as displayed in photo. |
|     | 2.3 shorted | Pin 8 is controlled by the KK controller.                                     |
| P2: | 1-2 Shorted | RTS and CTS in the RS232 connector is shorted (Default)                       |
|     | 1-2 Open    | RTS and CTS is controlled by the KK controller.                               |
| P4: | 1-2 Shorted | DSR and DTR in the RS232 connector is shorted. (Default)                      |
|     | 1-2 Open    | DSR and DTR is controlled by the KK controller.                               |

## RS 232 communication

---

Be aware when mounting the card that the last pin on the C5 connector is outside the socket of the WICotech board

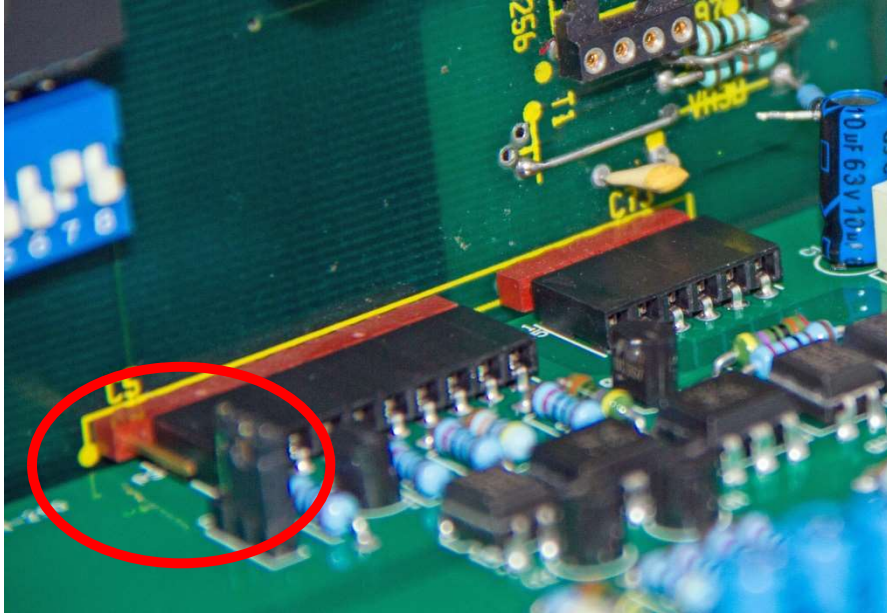

#### 4. Cable

##### 4.1. Cable layout for F2403

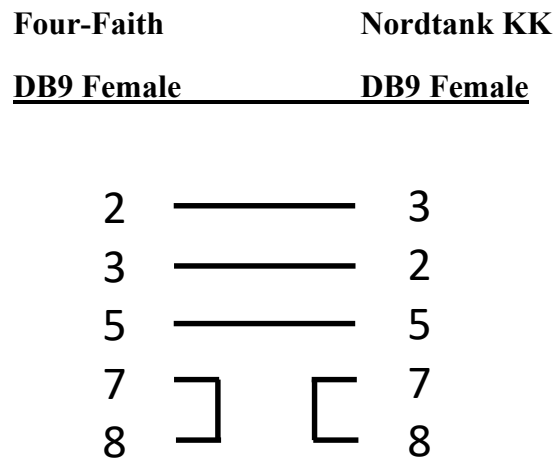

This cable is the same as the standard Four-Faith (Black) communication cable.

#### 4.2. Cable layout for F2816 - COM 1

| Four-Faith 2816 |       | WTC1              |       |
|-----------------|-------|-------------------|-------|
| <u>Terminal</u> |       | <u>DB9 Female</u> |       |
| 3               | ————— | 3                 | White |
| 4               | ————— | 2                 | Green |
| 5               | ————— | 5                 | Brown |
| 1 PWR           |       | 7                 |       |
| 2 GND           |       | 8                 |       |

#### 4.3. Cable layout for F2816 - COM 2

| Four-Faith 2816 |       | WTC1              |       |
|-----------------|-------|-------------------|-------|
| <u>Terminal</u> |       | <u>DB9 Female</u> |       |
| 6               | ————— | 3                 | White |
| 7               | ————— | 2                 | Green |
| 5               | ————— | 5                 | Brown |
| 1 PWR           |       | 7                 |       |
| 2 GND           |       | 8                 |       |

The Power (PWR) must be between +5V to +36V DC (Standard power supply is 12V DC)

An easy way to check if the wires on pin 3 and 4 (COM1) or pin 6 and 7 (COM2) is mounted correct is to measure the DC voltage on both pins in reference to GND (pin 5). If the Rx and Tx wires are mounted correct, should it be possible to measure a voltage on both pins (Above 3 volts). If there is only voltage on one pin is the wires wrong and they must be flipped.

## 5. Four Faith – Signal monitoring

### 5.1. F2403 Signal monitoring

The Four Faith F2403 GPRS modem can be used to monitor the signal strength during installation.

This can be done on units bought after October 2014 and with firmware versions after this date.

The Signal mode is activated using a special DB9 adaptor that is inserted into the RS232 port on the Four Faith modem. When the adaptor is inserted will the online LED on the modem not display the online status anymore but instead will the signal strength be display. The signal level is illustrated by a number of blinks that is repeated every 3 seconds.

There are 5 different blink levels.

| Level | Signal strength (dBm) | Quality   |
|-------|-----------------------|-----------|
| 1     | -113 -> -103          | Bad       |
| 2     | -101 -> -95           | Marginal  |
| 3     | -93 -> -85            | OK        |
| 4     | -83 -> -75            | Good      |
| 5     | -73 or higher         | Excellent |



The GPRS modem will not attempt to connect unless the signal strength is 2 or above but the signal should be no less than 3 or more before a stable connection can be expected.

Be aware that when the Signal tester adaptor is inserted will the modem NOT attempt to go online. The modem will return to normal operation when the adaptor is removed.

## 5.2. F2816 Signal monitoring

The Four Faith F2816 GPRS modem can be used to monitor the signal strength during installation.

The Signal mode is activated by pressing the signal tester button on the “Multiport interface” unit. The button has to be kept pressed during the signal testing.

If the kit is not equipped with the signal tester button can the signal mode be activated by connecting pin 11 (IO2) to the ground pin 2 or 5.

When the connection is established will the online LED on the modem not display the online status anymore but instead will the signal strength be display. The signal level is illustrated by a number of blinks that is repeated every 3 seconds.

There are 5 different blink levels.

| Level | Signal strength (dBm) | Quality   |
|-------|-----------------------|-----------|
| 1     | -113 -> -103          | Bad       |
| 2     | -101 -> -95           | Marginal  |
| 3     | -93 -> -85            | OK        |
| 4     | -83 -> -75            | Good      |
| 5     | -73 or higher         | Excellent |



The GPRS modem will not attempt to connect unless the signal strength is 2 or above but the signal should be no less than 3 or more before a stable connection can be expected.

Be aware that when the Signal tester is active will the modem NOT show the online signal anymore. The modem will return to normal operation when the adaptor is removed.